

# Agilent E1343A 16-Channel GP High-Voltage Relay Multiplexer

## Data Sheet

- 1-Slot, B-size, register based
- General purpose, high-voltage relay multiplexer
- High-voltage measurements up to 250 V
- 16-channel 3-wire or 8-channel 4-wire multiplexer
- Shunt/series signal conditioning elements
- Channel scanning with Agilent DMMs

### Configuration

The multiplexer is arranged into two banks of eight switches, each having its own common high, low, and guard screw terminals accessible on the terminal block. Tree-switched common high, low, and guard screw terminals and analog bus connections provide access to all 16 channels. Closing the channel switches and tree switches using the SCPI command [ROUTe:]CLOSe operates the module as either a single 1x16 three-wire multiplexer, two independent 1x8 three-wire multiplexers (for four-wire  $\Omega$ ), or a 1x8 six-wire multiplexer. The E1343A component card is also used in the E1344A.

One analog bus cable is shipped with each module, making it easy to connect common outputs together for slot-adjacent modules. If you are using a B-size mainframe, Agilent E1300B or E1301B, use the analog bus cable shipped with the E1326B DMM to connect it to the multiplexer(s).

### C-size Adapter

For installing the E1343A in a C-size mainframe, the E1403C active adapter is recommended.

### Product Specifications

#### Input

##### DC:

Maximum voltage (any terminal to any other terminal or chassis): 250 Vdc

##### AC rms:

Maximum voltage (any terminal to any other terminal or chassis): 250 V rms

Maximum current (per channel common, non-inductive): 50 mA

Maximum power per channel: 1 VA

#### DC

Maximum thermal offset per channel, differential

Hi-Lo: 10  $\mu$ V

Closed channel resistance: 100  $\Omega \pm 10\%$

Insulation resistance (between any two points): 10E9  $\Omega$

Insulation resistance (Hi to Lo, power off): n/a

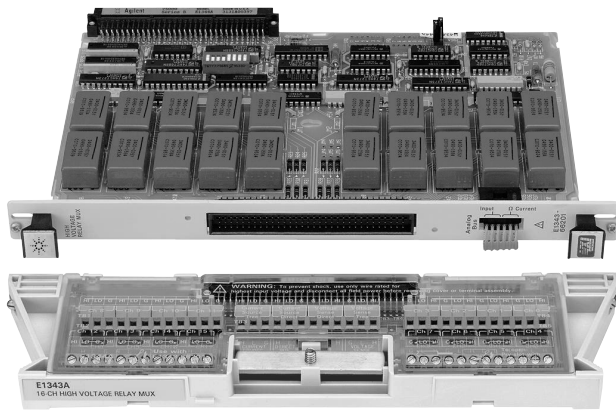
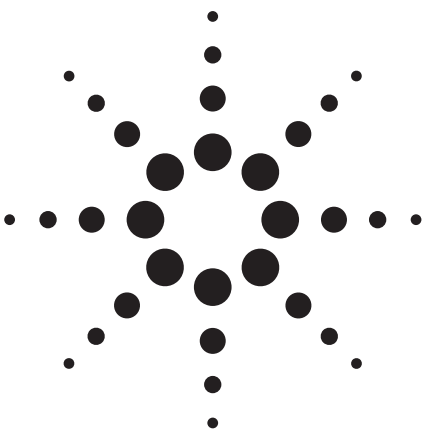

Agilent E1343A

### Description

The Agilent E1343A General-Purpose Reed Relay Multiplexer is a **B-size, 1-slot, register-based Agilent VXI module with high-voltage capability**. It switches 16 channels of high, low, and guard each. This multiplexer consists of a B-size component card (labeled E1343-66201) and a screw terminal block that plugs onto the component card. The E1343A is functionally similar to the E1344A.

Tree-switched common high, low, and guard screw terminals and analog bus connections provide access to all 16 channels. This module can operate as either a single 1x16 three-wire multiplexer, two independent 1x8 three-wire multiplexers (for four-wire  $\Omega$ ), or a 1x8 six-wire multiplexer.

Refer to the Agilent Technologies Website for instrument driver availability and downloading instructions, as well as for recent product updates, if applicable.

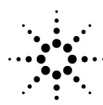

**Agilent Technologies**

Innovating the HP Way

## AC

<b>Minimum bandwidth</b> (-3 dB, 50 Ω source/load):	10 MHz (protection resistors shorted)
<b>Crosstalk (channel-to-channel):</b>	
100 kHz:	-80 dB
10 MHz:	-40 dB
Both:	n/a
<b>Closed channel capacitance:</b>	<150 pF Hi-Lo, <150 pF Lo-Guard, <2000 pF Guard-Chassis

## General Characteristics

<b>Relays:</b>	Reed relays Break-before-make
<b>Power down state:</b>	Relays open on power down
<b>Power up state:</b>	Relays open on power up
<b>Minimum relay life:</b>	
<b>No load:</b>	10E8 operations
<b>Rated load:</b>	10E7 operations
<b>Screw terminal wire size:</b>	16 to 26 AWG (1.5, 1.2, 0.9, 0.75, 0.5 mm)
<b>Scanning rate:</b>	350 channels/s typ.

## VXI Characteristics

<b>VXI device type:</b>	Register based, A16, slave only
<b>Size:</b>	B
<b>Slots:</b>	1
<b>Connectors:</b>	P1
<b>Shared memory:</b>	None
<b>VXI busses:</b>	None
<b>C-size compatibility:</b>	Requires E1403C

## Instrument Drivers

See the Agilent Technologies Website ([http://www.agilent.com/find/inst\\_drivers](http://www.agilent.com/find/inst_drivers)) for driver availability and downloading.

<b>Command module firmware:</b>	Downloadable
<b>Command module firmware rev:</b>	A.06
<b>I-SCPI Win 3.1:</b>	Yes
<b>I-SCPI Series 700:</b>	Yes
<b>C-SCPI LynxOS:</b>	Yes
<b>C-SCPI Series 700:</b>	Yes
<b>Panel Drivers:</b>	Yes
<b>VXIplug&amp;play Win Framework:</b>	Yes
<b>VXIplug&amp;play Win 95/NT Framework:</b>	Yes
<b>VXIplug&amp;play HP-UX Framework:</b>	No

## Module Current

	$I_{PM}$	$I_{DM}$
+5 V:	0.2	0.01
+12 V:	0.13	0.01
-12 V:	0	0
+24 V:	0	0
-24 V:	0	0
-5.2 V:	0	0
-2 V:	0	0

## Cooling/Slot

<b>Watts/slot:</b>	1.00
<b>ΔP mm H<sub>2</sub>O:</b>	0.02
<b>Air Flow liter/s:</b>	0.10

## Ordering Information

Description	Product No.
16-Channel High Voltage Relay Multiplexer	E1343A
Service Manual	E1343A 0B3
3 Yr. Retn. to Agilent to 1 Yr. OnSite Warr.	E1343A W01
E1343A Screw Terminal Module	E1343-80001

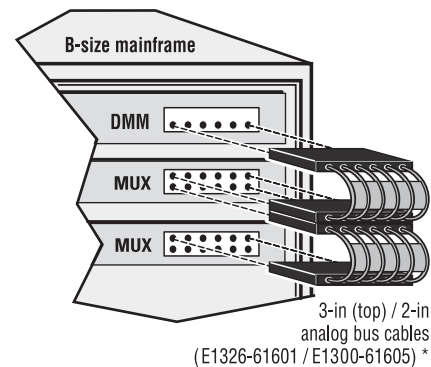

Analog bus cables for MUX-to-MUX and MUX-to-multimeter connections

19.5-in analog bus cable to internal DMM  
(E1326-61611) \*\*

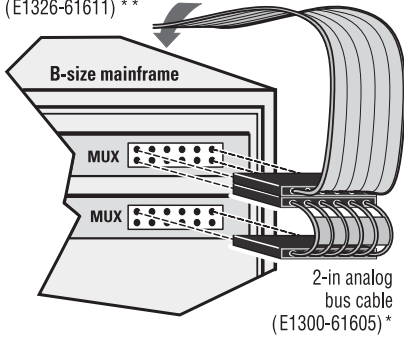

\* DMM-to-MUX and MUX-to-MUX analog bus cables are provided with the purchase of the DMM and MUX modules respectively.

\*\* 19.5-in analog bus cable is provided with purchase of E1300/01B Series B mainframe with internal DMM option.

Analog bus cables for MUX-to-MUX and MUX-to-multimeter connections

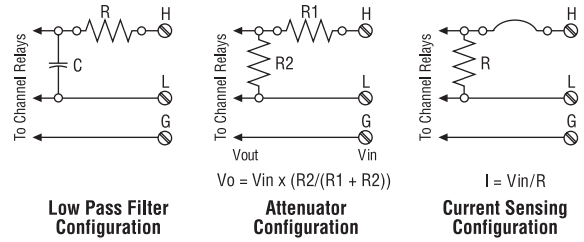

Signal Conditioning Components/Current Shunt

### E1343A Circuit Diagram

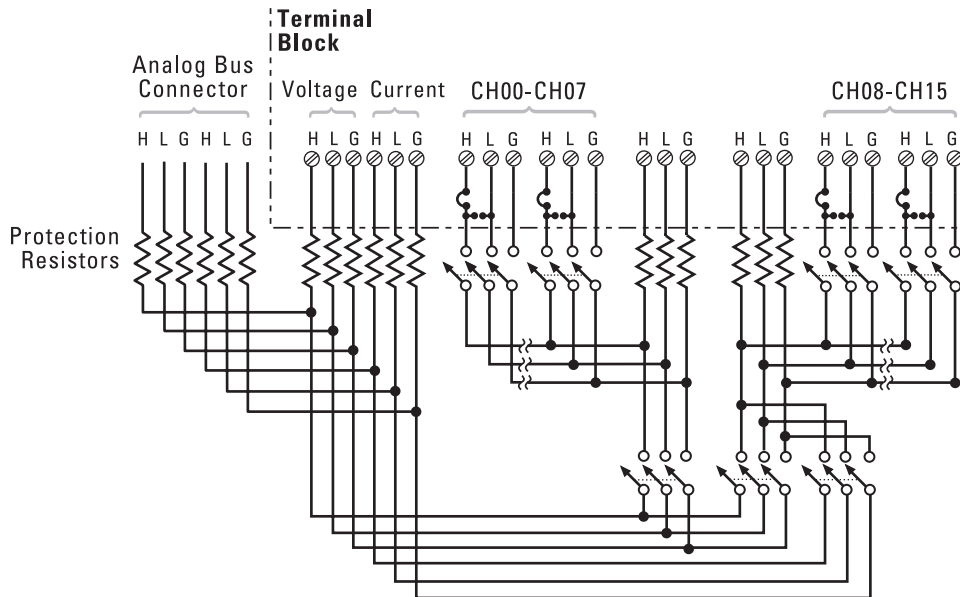

## Related Literature

*2000 Test System and VXI Catalog CD-ROM*,  
Agilent Pub. No. 5980-0308E (detailed specifications for VXI products)

*2000 Test System and VXI Catalog*,  
Agilent Pub. No. 5980-0307E (overview of VXI products )

*1998 Test System and VXI Products Data Book*,  
Agilent Pub. No. 5966-2812E

## Online

Internet access for Agilent product information, services and support  
[www.agilent.com/find/tmdir](http://www.agilent.com/find/tmdir)

VXI product information  
[www.agilent.com/find/vxi](http://www.agilent.com/find/vxi)

Defense Electronics Applications  
[www.agilent.com/find/defense\\_ATE](http://www.agilent.com/find/defense_ATE)

Agilent Technologies VXI Channel Partners  
[www.agilent.com/find/vxichanpart](http://www.agilent.com/find/vxichanpart)

Agilent Technologies' HP VEE Application Website  
[www.agilent.com/find/vee](http://www.agilent.com/find/vee)

Agilent Technologies Data Acquisition and Control Website  
[www.agilent.com/find/data\\_acq](http://www.agilent.com/find/data_acq)

Agilent Technologies Instrument Driver Downloads  
[www.agilent.com/find/inst\\_drivers](http://www.agilent.com/find/inst_drivers)

Agilent Technologies Electronics Manufacturing Test Solutions  
[www.agilent.com/go/manufacturing](http://www.agilent.com/go/manufacturing)

**Get assistance with all your test and measurement needs at  
[www.agilent.com/find/assist](http://www.agilent.com/find/assist)  
or check your local phone book for the Agilent office  
near you.**

## Agilent Technologies' test and measurement service/support commitment

Agilent strives to maximize the value our test and measurement products give you, while minimizing your risk and service/support problems. We work to ensure that each product is realistically described in the literature, meets its stated performance and functionality, has a clearly stated global warranty, and is supported at least five years beyond its production life. Our extensive self-help tools include many online resources ([www.agilent.com](http://www.agilent.com)).

Experienced Agilent test engineers throughout the world offer practical recommendations for product evaluation and selection. After you purchase an Agilent product, they can provide no-charge assistance with operation verification and basic measurement setups for advertised capabilities. To enhance the features, performance, and flexibility of your test and measurement products—and to help you solve application challenges—Agilent offers free or extra-cost product options and upgrades, and sell expert engineering, calibration, and other consulting services.

### Phone and fax

United States:  
Agilent Technologies  
(tel) 1 800 452 4844

Canada:  
Agilent Technologies Canada Inc.  
(tel) 1 877 894 4414

Europe:  
Agilent Technologies  
Test & Measurement  
European Marketing Organisation  
(tel) (31 20) 547 2000

Japan:  
Agilent Technologies Japan Ltd.  
(tel) (81) 426 56 7832  
(fax) (81) 426 56 7840

Latin America:  
Agilent Technologies  
Latin American Region Headquarters, U.S.A.  
(tel) (305) 267 4245  
(fax) (305) 267 4286

Australia/New Zealand:  
Agilent Technologies Australia Pty Ltd.  
(tel) 1 800 629 485 (Australia)  
(fax) (61 3) 9272 0749  
(tel) 0 800 738 378 (New Zealand)  
(fax) (64 4) 802 6881

Asia Pacific:  
Agilent Technologies, Hong Kong  
(tel) (852) 3197-7777  
(fax) (852) 2506-9284

Data Subject to Change  
© Agilent Technologies 2000  
Printed in the U.S.A. 04/2000  
Publication No.: 5965-5599E



**Agilent Technologies**  
Innovating the HP Way